

DPAE-Si-pin is a high performance semiconductor detector with high energy resolution and excellent cost performance.

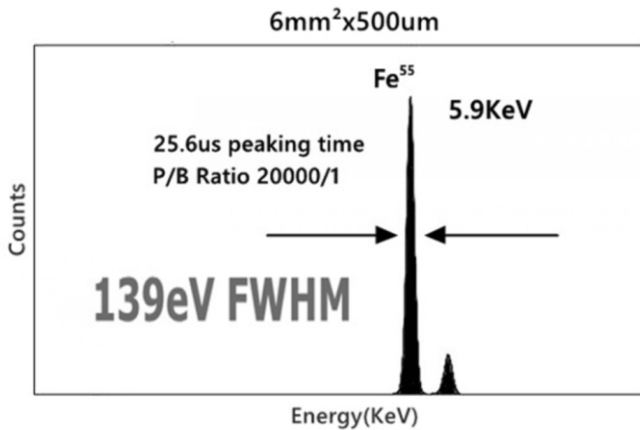
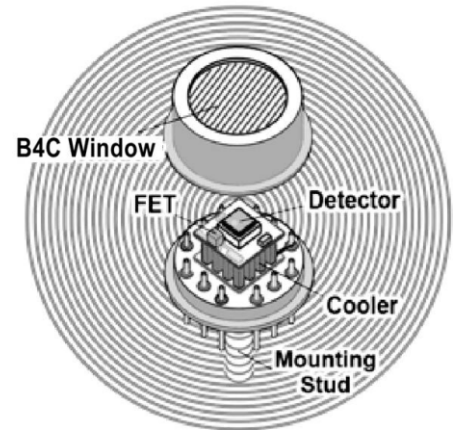

Figure 1. Fe55 Spectrum with DPAE-Si-pin Detector



Features:

- 139eV FWHM Resolution @ 5.9 keV
- Silicon Thickness 500 μm
- Size 6-25mm²
- Energy Range 1Kev-40KeV
- Interface : USB, RS232, Ethernet
- No Liquid Nitrogen

Applications:

- X-Ray Fluorescence
- RoHS / WEEE Compliance XRF
- OEM & Special Applications
- Process Control
- Research

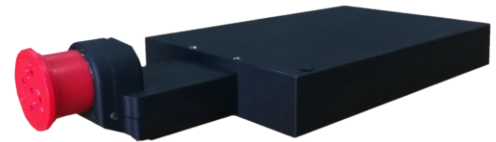

DPAE-Si-pin Detector Includes:

- 1 Si-pin Detector and Preamplifier
- 2 Digital Pulse Analyzer (with Power)

General Specifications

Detector Type	DPAAE-Si-pin Detector
Detector Size	6-25mm ²
Silicon Thickness	500μm
Energy Resolution @5.9keV(Fe55)	139-260eV FWHM
Energy Range	1 Kev-40 Kev, 1.5Kev-25Kev (Efficiency >25%)
Detector Window Thickness	3.5 μm / 1 mil (25 μm)
Collimator	Internal Multi Layer Collimator (ML)
Charge Sensitive Preamplifier	custom design with reset
Gain Stability	<20 ppm/°C (typical)
Nitrogen	Level 2
Case Size	See the Size Drawing
Weight	220g
Total Power	4.2-8.5VDC
Warranty Period	1 year
Lifetime Typical	5 to 10 years, depending on use
Storage & Shipping	Long-term Storage: 10+ years in dry environment Typical Storage & Shipping: -20°C to+50°C, 10 to 90% humidity Operation conditions noncondensing
Operation conditions	0°C -50°C

This DPAAE-Si-pin detector enables extremely high energy resolution and excellent cost performance. Its high performance, small size, and low cost make it to be an ideal detector for X-ray fluorescence spectrometer.

Use of Collimators

Most of detectors contain internal collimators to improve spectral quality. X-rays interacting near the edges of the active volume of the detector may produce small pulses due to the partial charge collection.

For some applications, these pulses result in artifacts in the spectrum which obscure the signal of interest. The internal collimator restricts X-rays to the active volume, where clean signals are produced. Depending on the type of detector, collimators can improve peak to background(P/B), eliminate edge effects, and eliminate false peaks.

Additional System Information and Performance

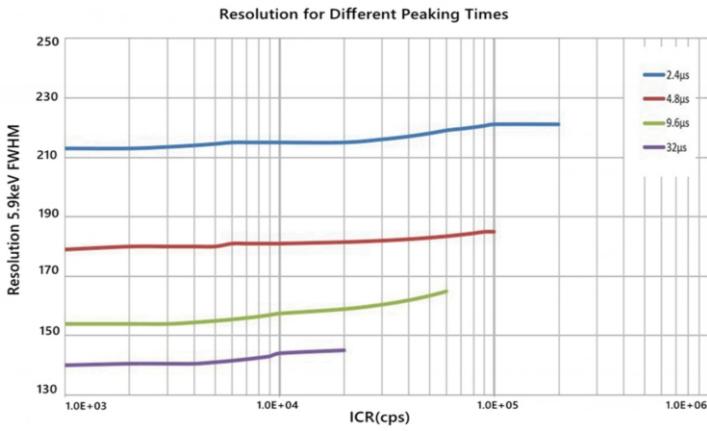

Figure 2. Resolution VS Input Count Rate (with different peaking time)

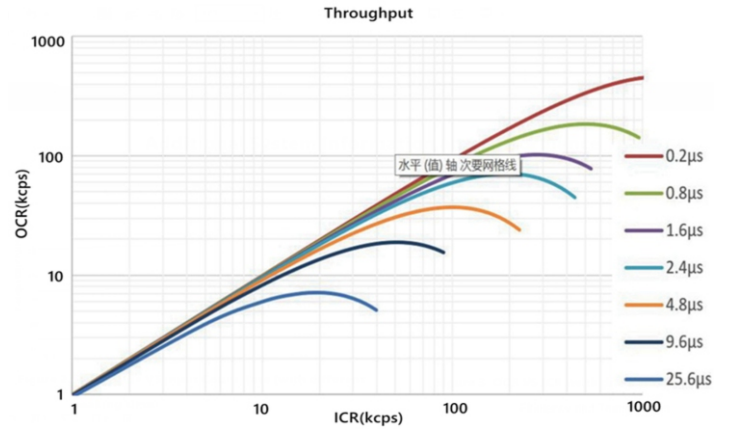

Figure 3. OCR VS ICR (with different peaking time)

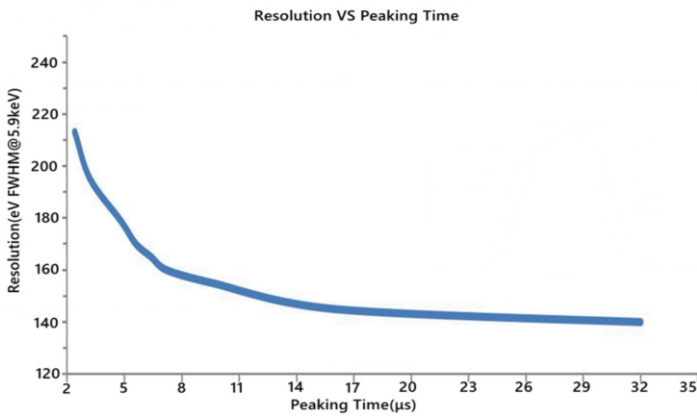

Figure 4. Resolution VS Peaking Time

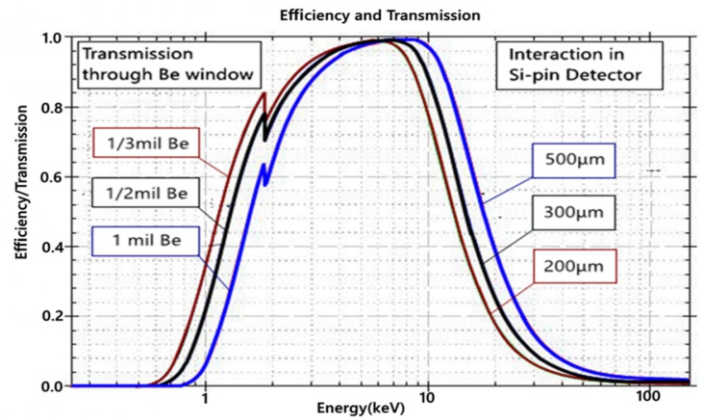
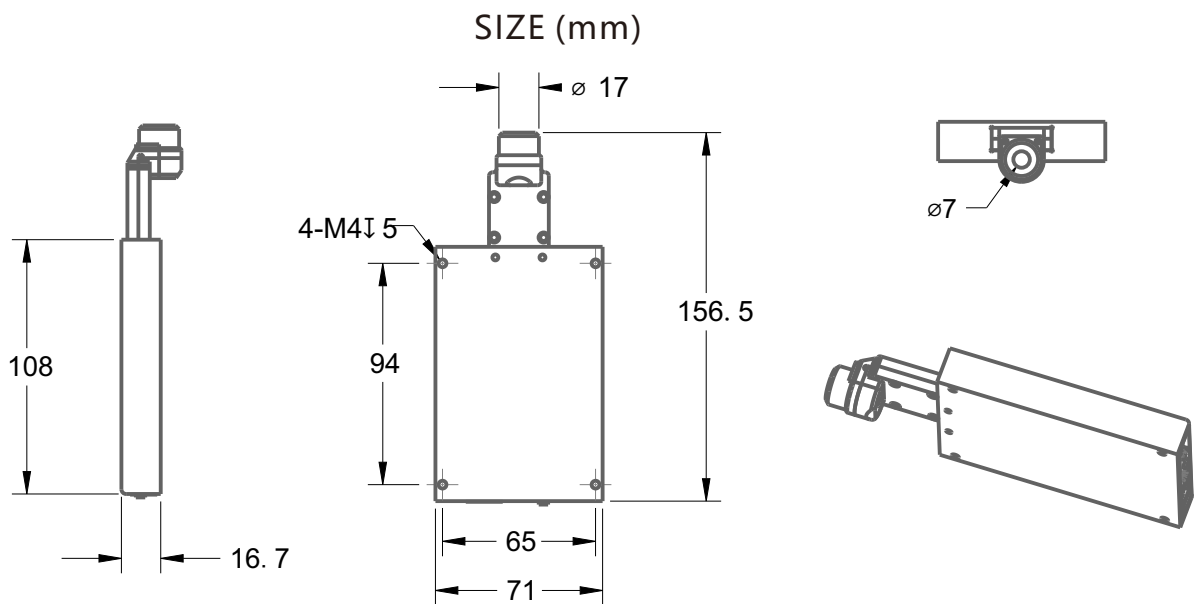

Figure 5. Efficiency and Transmission



Application Spectra (6mm²/500μm Si-pin)

